

SECTION **INT**  
INTERIOR

A  
B  
C  
D  
E  
F  
G  
H  
I  
INT  
K  
L  
M  
N  
O  
P

CONTENTS

<b>SYMPTOM DIAGNOSIS</b> .....	2	Exploded View .....	12
<b>SQUEAK AND RATTLE TROUBLE DIAG- NOSES</b> .....	2	Removal and Installation .....	12
Work Flow .....	2	<b>BODY SIDE TRIM</b> .....	15
Inspection Procedure .....	4	Exploded View .....	15
Diagnostic Worksheet .....	6	Removal and Installation .....	15
<b>PRECAUTION</b> .....	8	<b>REAR PARCEL SHELF FINISHER</b> .....	19
<b>PRECAUTIONS</b> .....	8	Exploded View .....	19
Precaution for Supplemental Restraint System (SRS) "AIR BAG" and "SEAT BELT PRE-TEN- SIONER" .....	8	Removal and Installation .....	19
Precautions Necessary for Steering Wheel Rota- tion After Battery Disconnection .....	8	<b>FLOOR TRIM</b> .....	21
Precaution for Procedure without Cowl Top Cover.....	9	Exploded View .....	21
Precaution for Battery Service .....	9	Removal and Installation .....	21
Precaution for Work .....	9	<b>HEADLINING</b> .....	23
<b>PREPARATION</b> .....	10	<b>NORMAL ROOF</b> .....	23
<b>PREPARATION</b> .....	10	NORMAL ROOF : Exploded View .....	23
Special Service Tools .....	10	NORMAL ROOF : Removal and Installation .....	24
Commercial Service Tools .....	10	<b>SUNROOF</b> .....	25
<b>CLIP LIST</b> .....	11	SUNROOF : Exploded View .....	26
Clip List .....	11	SUNROOF : Removal and Installation .....	26
<b>REMOVAL AND INSTALLATION</b> .....	12	<b>TRUNK ROOM TRIM</b> .....	29
<b>DOOR FINISHER</b> .....	12	Exploded View .....	29
		Removal and Installation .....	29
		<b>TRUNK LID TRIM</b> .....	31
		Exploded View .....	31
		Removal and Installation .....	31

# SQUEAK AND RATTLE TROUBLE DIAGNOSES

< SYMPTOM DIAGNOSIS >

## SYMPTOM DIAGNOSIS

### SQUEAK AND RATTLE TROUBLE DIAGNOSES

#### Work Flow

INFOID:000000006456817

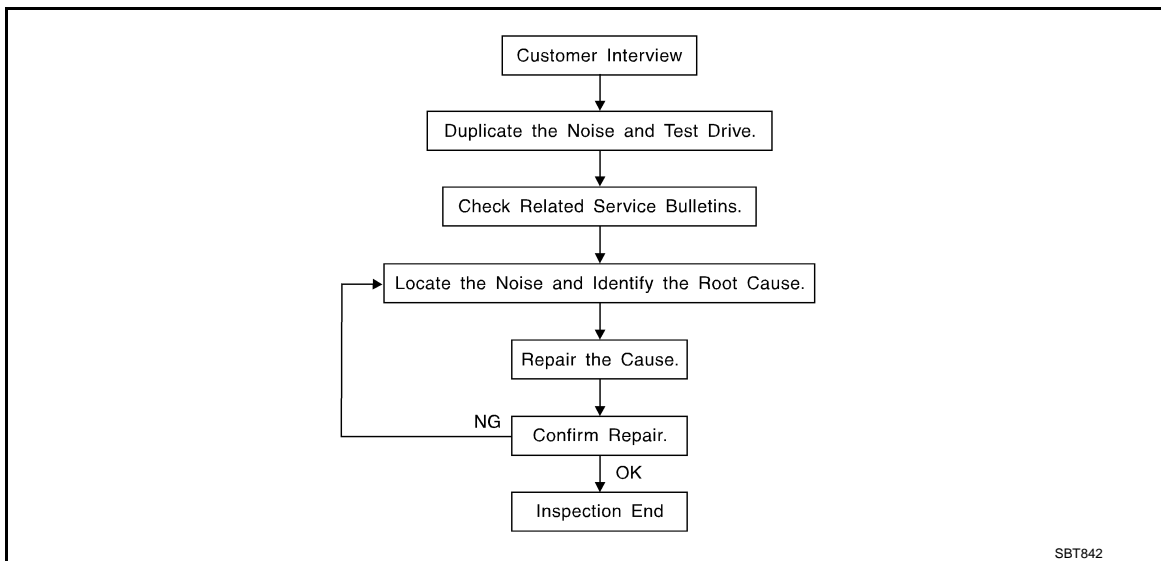

#### CUSTOMER INTERVIEW

Interview the customer if possible, to determine the conditions that exist when the noise occurs. Use the Diagnostic Worksheet during the interview to document the facts and conditions when the noise occurs and any customer comments. Refer to [INT-6. "Diagnostic Worksheet"](#). This information is necessary to duplicate the conditions that exist when the noise occurs.

- The customer may not be able to provide a detailed description or the location of the noise. Attempt to obtain all the facts and conditions that exist when the noise occurs (or does not occur).
- If there is more than one noise in the vehicle, perform a diagnosis and repair the noise that the customer is concerned about. This can be accomplished by performing a test drive with the customer.
- After identifying the type of noise, isolate the noise in terms of its characteristics. The noise characteristics are provided so that the customer, service adviser, and technician use the same language when describing the noise.
- Squeak – (Like tennis shoes on a clean floor)  
Squeak characteristics include the light contact / fast movement / brought on by road conditions / hard surfaces = high-pitched noise / softer surfaces = low-pitched noises / edge to surface = chirping
- Creak – (Like walking on an old wooden floor)  
Creak characteristics include firm contact / slow movement/twisting with a rotational movement / pitch dependent on materials / often brought on by activity.
- Rattle – (Like shaking a baby rattle)  
Rattle characteristics include fast repeated contact / vibration or similar movement / loose parts/missing clip or fastener / incorrect clearance.
- Knock – (Like a knock on a door)  
Knock characteristics include hollow sounds / sometimes repeating / often brought on by driver action.
- Tick – (Like a clock second hand)  
Tick characteristics include gentle contacting of light materials / loose components / can be caused by driver action or road conditions.
- Thump – (Heavy, muffled knock noise)  
Thump characteristics include softer knock / dull sounds often brought on by activity.
- Buzz – (Like a bumblebee)  
Buzz characteristics include high frequency rattle / firm contact.
- Often the degree of acceptable noise level varies depending upon the person. A noise that a technician may judge as acceptable may be very irritating to a customer.
- Weather conditions, especially humidity and temperature, may have a great effect on noise level.

#### DUPLICATE THE NOISE AND TEST DRIVE

# SQUEAK AND RATTLE TROUBLE DIAGNOSES

## < SYMPTOM DIAGNOSIS >

If possible, drive the vehicle with the customer until the noise is duplicated. Note any additional information on the Diagnostic Worksheet regarding the conditions or location of the noise. This information can be used to duplicate the same conditions when the repair is reconfirmed.

If the noise can be duplicated easily during the test drive, do the following with the vehicle stopped to help identify the source of the noise.

- 1) Close a door.
  - 2) Tap or push/pull around the area where the noise appears to be coming from.
  - 3) Rev the engine.
  - 4) Use a floor jack to recreate vehicle "twist".
  - 5) At idle, apply engine load (electrical load, half-clutch on M/T models, drive position on A/T models).
  - 6) Raise the vehicle on a hoist and hit a tire with a rubber hammer.
- Drive the vehicle and attempt to duplicate the conditions the customer states exist when the noise occurs.
  - If it is difficult to duplicate the noise, drive the vehicle slowly on an undulating or rough road to stress the vehicle body.

## CHECK RELATED SERVICE BULLETINS

After verifying the customer concern or symptom, check ASIST for Technical Service Bulletins (TSBs) related to the concern or symptom.

If a TSB relates to the symptom, follow the procedure to repair the noise.

## LOCATE THE NOISE AND IDENTIFY THE ROOT CAUSE

1. Narrow down the noise to a general area. To help pinpoint the source of the noise, use a listening tool (Chassis ear: J-39570, engine ear, and mechanics stethoscope).
2. Narrow down the noise to a more specific area and identify the cause of the noise by:
  - Removing the component(s) in the area(s) that is / are suspected to be the cause of the noise. Do not use too much force when removing clips and fasteners, otherwise clips and fasteners can be broken or lost during the repair, creating a new noise.
  - Tapping or pushing/pulling the component(s) that is / are suspected to be the cause of the noise. Do not tap or push/pull the component(s) with excessive force, otherwise the noise is eliminated only temporarily.
  - Feeling for a vibration by hand by touching the component(s) that is / are suspected to be the cause of the noise.
  - Placing a piece of paper between components that are suspected to be the cause of the noise.
  - Looking for loose components and contact marks.  
Refer to [INT-4, "Inspection Procedure"](#).

## REPAIR THE CAUSE

- If the cause is a loose component, tighten the component securely.
- If the cause is insufficient clearance between components:
  - Separate components by repositioning or loosening and retightening the components, if possible.
  - Insulate components with a suitable insulator such as urethane pads, foam blocks, felt cloth tape, or urethane tape. A NISSAN Squeak and Rattle Kit (J-43980) is available through the authorized NISSAN Parts Department.

### **CAUTION:**

**Never use excessive force as many components are constructed of plastic and may be damaged.**

### **NOTE:**

Always check with the Parts Department for the latest parts information.

The following materials are contained in the NISSAN Squeak and Rattle Kit (J-43980). Each item can be ordered separately as needed.

URETHANE PADS [1.5 mm (0.059 in) thick]

Insulates connectors, harness, etc.

- 76268-9E005: 100 × 135 mm (3.937 × 5.315 in)
- 76884-71L01: 60 × 85 mm (2.362 × 3.346 in)
- 76884-71L02: 15 × 25 mm (0.591 × 0.984 in)

INSULATOR (Foam blocks)

Insulates components from contact. Can be used to fill space behind a panel.

- 73982-9E000: 45 mm (1.772 in) thick, 50 × 50 mm (1.969 × 1.969 in)
- 73982-50Y00: 10 mm (0.394 in) thick, 50 × 50 mm (1.969 × 1.969 in)

INSULATOR (Light foam block)

80845-71L00: 30 mm (1.18 in) thick, 30 × 50 mm (1.181 × 1.969 in)

FELT CLOTHTAPE

# SQUEAK AND RATTLE TROUBLE DIAGNOSES

## < SYMPTOM DIAGNOSIS >

---

Used to insulate where movement does not occur. Ideal for instrument panel applications.

- 68370-4B000: 15 × 25 mm (0.591 × 0.984 in) pad
- 68239-13E00: 5 mm (0.197 in) wide tape roll

The following materials, not found in the kit, can also be used to repair squeaks and rattles.

### UHMW (TEFLON) TAPE

Insulates where slight movement is present. Ideal for instrument panel applications.

### SILICONE GREASE

Used in place of UHMW tape that is visible or does not fit. Only lasts a few months.

### SILICONE SPRAY

Used when grease cannot be applied.

### DUCT TAPE

Used to eliminate movement.

## CONFIRM THE REPAIR

After repair is complete, test drive the vehicle to confirm that the cause of noise is repaired by test driving the vehicle. Operate the vehicle under the same conditions as when the noise originally occurred. Refer to the notes on the Diagnostic Worksheet.

## Inspection Procedure

INFOID:000000006456818

Refer to Table of Contents for specific component removal and installation information.

## INSTRUMENT PANEL

Most incidents are caused by contact and movement between:

1. The cluster lid A and instrument panel
2. Acrylic lens and combination meter housing
3. Instrument panel to front pillar garnish
4. Instrument panel to windshield
5. Instrument panel mounting pins
6. Wiring harnesses behind the combination meter
7. A/C defroster duct and duct joint

These incidents can usually be located by tapping or moving the components to duplicate the noise or by pressing on the components while driving to stop the noise. Most of these incidents can be repaired by applying felt cloth tape or silicon spray (in hard to reach areas). Urethane pads can be used to insulate wiring harness.

### **CAUTION:**

**Never use silicone spray to isolate a squeak or rattle. If the area is saturated with silicone, the recheck of repair becomes impossible.**

## CENTER CONSOLE

Components to check include:

1. Shifter assembly cover to finisher
2. A/C control unit and cluster lid C
3. Wiring harnesses behind audio and A/C control unit

The instrument panel repair and isolation procedures also apply to the center console.

## DOORS

Check the following items:

1. Finisher and inner panel making a slapping noise
2. Inside handle escutcheon connection to door finisher
3. Wiring harnesses tapping
4. Door striker out of alignment causing a popping noise on starts and stops

Tapping, moving the components, or pressing on them while driving to duplicate the conditions can isolate many of these incidents. The areas can usually be insulated with felt cloth tape or insulator foam blocks from the NISSAN Squeak and Rattle Kit (J-43980) to repair the noise.

## TRUNK

Trunk noises are often caused by a loose jack or loose items put into the trunk by the customer.

In addition check for the following items:

# SQUEAK AND RATTLE TROUBLE DIAGNOSES

## < SYMPTOM DIAGNOSIS >

---

1. Trunk lid dumpers out of adjustment
2. Trunk lid striker out of adjustment
3. Trunk lid torsion bars knocking together
4. A loose license plate or bracket

Most of these incidents can be repaired by adjusting, securing, or insulating the item(s) or component(s) causing the noise.

## SUNROOF/HEADLINING

Noises in the sunroof / headlining area can often be traced to one of the following items:

1. Sunroof lid, rail, linkage, or seals making a rattle or light knocking noise
2. Sunvisor shaft shaking in the holder
3. Front or rear windshield touching headlining and squeaking

Again, pressing on the components to stop the noise while duplicating the conditions can isolate most of these incidents. Repairs usually consist of insulating with felt cloth tape.

## SEATS

When isolating seat noise it is important to note the position the seat is in and the load placed on the seat when the noise occurs. These conditions should be duplicated when verifying and isolating the cause of the noise.

Causes of seat noise include:

1. Headrest rods and holder
2. A squeak between the seat pad cushion and frame
3. The rear seatback lock and bracket

These noises can be isolated by moving or pressing on the suspected components while duplicating the conditions under which the noise occurs. Most of these incidents can be repaired by repositioning the component or applying urethane tape to the contact area.

## UNDERHOOD

Some interior noise may be caused by components under the hood or on the engine wall. The noise is then transmitted into the passenger compartment.

Causes of transmitted underhood noise include:

1. Any component mounted to the engine wall
2. Components that pass through the engine wall
3. Engine wall mounts and connectors
4. Loose radiator mounting pins
5. Hood bumpers out of adjustment
6. Hood striker out of adjustment

These noises can be difficult to isolate since they cannot be reached from the interior of the vehicle. The best method is to secure, move, or insulate one component at a time and test drive the vehicle. Also, engine RPM or load can be changed to isolate the noise. Repairs can usually be made by moving, adjusting, securing, or insulating the component causing the noise.

A

B

C

D

E

F

G

H

I

INT

K

L

M

N

O

P

# SQUEAK AND RATTLE TROUBLE DIAGNOSES

< SYMPTOM DIAGNOSIS >

## Diagnostic Worksheet

INFOID:000000006456819



### SQUEAK & RATTLE DIAGNOSTIC WORKSHEET

Dear Infiniti Customer:

We are concerned about your satisfaction with your Infiniti vehicle. Repairing a squeak or rattle sometimes can be very difficult. To help us fix your Infiniti right the first time, please take a moment to note the area of the vehicle where the squeak or rattle occurs and under what conditions. You may be asked to take a test drive with a service consultant or technician to ensure we confirm the noise you are hearing.

#### I. WHERE DOES THE NOISE COME FROM? (circle the area of the vehicle)

The illustrations are for reference only, and may not reflect the actual configuration of your vehicle.

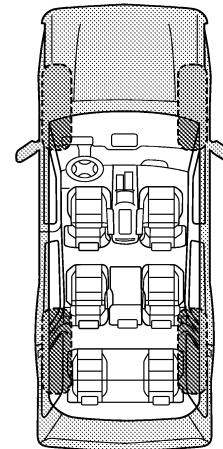
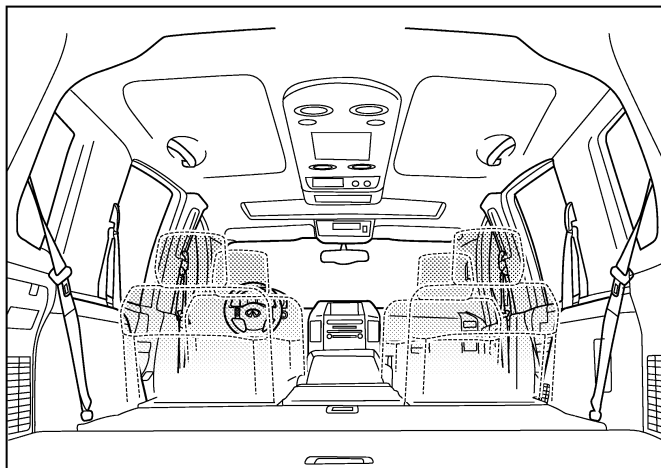
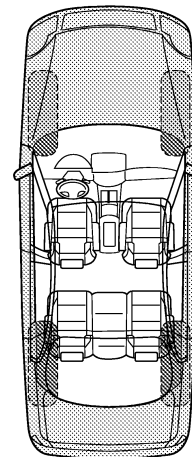
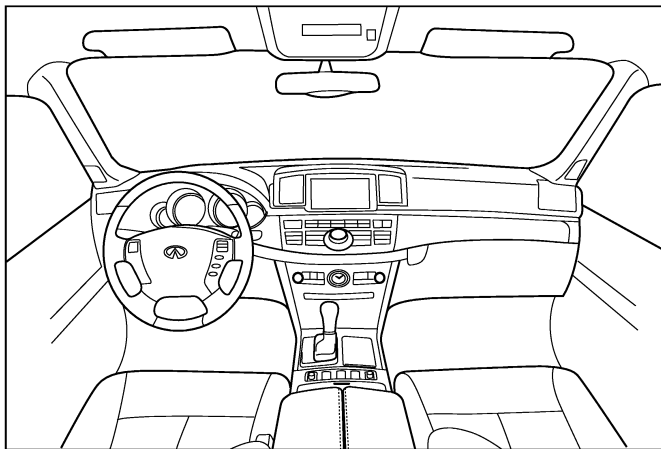

Continue to page 2 of the worksheet and briefly describe the location of the noise or rattle. In addition, please indicate the conditions which are present when the noise occurs.

PIIB8741E

# SQUEAK AND RATTLE TROUBLE DIAGNOSES

< SYMPTOM DIAGNOSIS >

## SQUEAK & RATTLE DIAGNOSTIC WORKSHEET - page 2

Briefly describe the location where the noise occurs:

---

---

### II. WHEN DOES IT OCCUR? (please check the boxes that apply)

- |   |  |
|---|--|
| <input type="checkbox"/> anytime                      | <input type="checkbox"/> after sitting out in the rain |
| <input type="checkbox"/> 1st time in the morning      | <input type="checkbox"/> when it is raining or wet     |
| <input type="checkbox"/> only when it is cold outside | <input type="checkbox"/> dry or dusty conditions       |
| <input type="checkbox"/> only when it is hot outside  | <input type="checkbox"/> other:                        |

### III. WHEN DRIVING:

- through driveways
- over rough roads
- over speed bumps
- only about \_\_\_\_ mph
- on acceleration
- coming to a stop
- on turns: left, right or either (circle)
- with passengers or cargo
- other: \_\_\_\_\_
- after driving \_\_\_\_ miles or \_\_\_\_ minutes

### IV. WHAT TYPE OF NOISE

- squeak (like tennis shoes on a clean floor)
- creak (like walking on an old wooden floor)
- rattle (like shaking a baby rattle)
- knock (like a knock at the door)
- tick (like a clock second hand)
- thump (heavy, muffled knock noise)
- buzz (like a bumble bee)

### TO BE COMPLETED BY DEALERSHIP PERSONNEL

#### Test Drive Notes:

---

---

---

	YES	NO	Initials of person performing
Vehicle test driven with customer	<input type="checkbox"/>	<input type="checkbox"/>	_____
- Noise verified on test drive	<input type="checkbox"/>	<input type="checkbox"/>	_____
- Noise source located and repaired	<input type="checkbox"/>	<input type="checkbox"/>	_____
- Follow up test drive performed to confirm repair	<input type="checkbox"/>	<input type="checkbox"/>	_____

VIN: \_\_\_\_\_ Customer Name: \_\_\_\_\_  
W.O.# \_\_\_\_\_ Date: \_\_\_\_\_

This form must be attached to Work Order

PIIB8742E

A  
B  
C  
D  
E  
F  
G  
H  
I  
INT  
K  
L  
M  
N  
O  
P

# PRECAUTIONS

< PRECAUTION >

## PRECAUTION

### PRECAUTIONS

#### Precaution for Supplemental Restraint System (SRS) "AIR BAG" and "SEAT BELT PRE-TENSIONER"

INFOID:000000006456820

The Supplemental Restraint System such as "AIR BAG" and "SEAT BELT PRE-TENSIONER", used along with a front seat belt, helps to reduce the risk or severity of injury to the driver and front passenger for certain types of collision. This system includes seat belt switch inputs and dual stage front air bag modules. The SRS system uses the seat belt switches to determine the front air bag deployment, and may only deploy one front air bag, depending on the severity of a collision and whether the front occupants are belted or unbelted. Information necessary to service the system safely is included in the "SRS AIR BAG" and "SEAT BELT" of this Service Manual.

#### **WARNING:**

Always observe the following items for preventing accidental activation.

- To avoid rendering the SRS inoperative, which could increase the risk of personal injury or death in the event of a collision that would result in air bag inflation, all maintenance must be performed by an authorized NISSAN/INFINITI dealer.
- Improper maintenance, including incorrect removal and installation of the SRS, can lead to personal injury caused by unintentional activation of the system. For removal of Spiral Cable and Air Bag Module, see "SRS AIR BAG".
- Never use electrical test equipment on any circuit related to the SRS unless instructed to in this Service Manual. SRS wiring harnesses can be identified by yellow and/or orange harnesses or harness connectors.

#### PRECAUTIONS WHEN USING POWER TOOLS (AIR OR ELECTRIC) AND HAMMERS

#### **WARNING:**

Always observe the following items for preventing accidental activation.

- When working near the Air Bag Diagnosis Sensor Unit or other Air Bag System sensors with the ignition ON or engine running, never use air or electric power tools or strike near the sensor(s) with a hammer. Heavy vibration could activate the sensor(s) and deploy the air bag(s), possibly causing serious injury.
- When using air or electric power tools or hammers, always switch the ignition OFF, disconnect the battery, and wait at least 3 minutes before performing any service.

#### Precautions Necessary for Steering Wheel Rotation After Battery Disconnection

INFOID:000000006456821

#### **CAUTION:**

Comply with the following cautions to prevent any error and malfunction.

- Before removing and installing any control units, first turn the ignition switch to the LOCK position, then disconnect both battery cables.
- After finishing work, confirm that all control unit connectors are connected properly, then re-connect both battery cables.
- Always use CONSULT to perform self-diagnosis as a part of each function inspection after finishing work. If a DTC is detected, perform trouble diagnosis according to self-diagnosis results.

For vehicle with steering lock unit, if the battery is disconnected or discharged, the steering wheel will lock and cannot be turned.

If turning the steering wheel is required with the battery disconnected or discharged, follow the operation procedure below before starting the repair operation.

#### OPERATION PROCEDURE

1. Connect both battery cables.

#### **NOTE:**

Supply power using jumper cables if battery is discharged.

2. Turn the ignition switch to ACC position.  
(At this time, the steering lock will be released.)
3. Disconnect both battery cables. The steering lock will remain released with both battery cables disconnected and the steering wheel can be turned.



# PRECAUTIONS

## < PRECAUTION >

4. Perform the necessary repair operation.
5. When the repair work is completed, re-connect both battery cables. With the brake pedal released, turn the ignition switch from ACC position to ON position, then to LOCK position. (The steering wheel will lock when the ignition switch is turned to LOCK position.)
6. Perform self-diagnosis check of all control units using CONSULT.

### Precaution for Procedure without Cowl Top Cover

INFOID:000000006456822

When performing the procedure after removing cowl top cover, cover the lower end of windshield with urethane, etc to prevent damage to windshield.

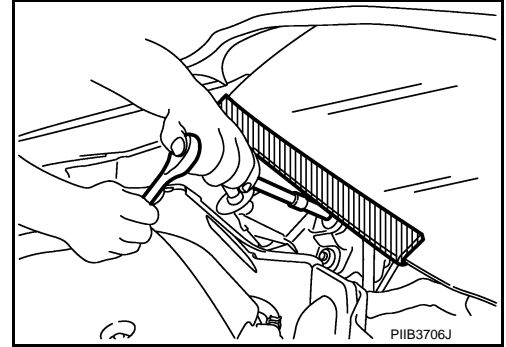

### Precaution for Battery Service

INFOID:000000006456823

Before disconnecting the battery, lower both the driver and passenger windows. This will prevent any interference between the window edge and the vehicle when the door is opened/closed. During normal operation, the window slightly raises and lowers automatically to prevent any window to vehicle interference. The automatic window function will not work with the battery disconnected.

### Precaution for Work

INFOID:000000006456824

- After removing and installing the opening/closing parts, be sure to carry out fitting adjustments to check their operation.
- Check the lubrication level, damage, and wear of each part. If necessary, grease or replace it.

A  
B  
C  
D  
E  
F  
G  
H  
I  
K  
L  
M  
N  
O  
P

INT

# PREPARATION

< PREPARATION >

## PREPARATION

### PREPARATION

#### Special Service Tools

INFOID:000000006456825

The actual shapes of Kent-Moore tools may differ from those of special service tools illustrated here.

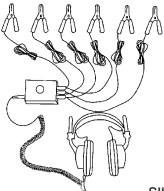
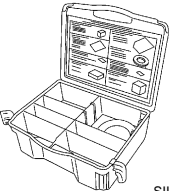
Tool number (Kent-Moore No.) Tool name	Description
(J-39570) Chassis ear   SIIA0993E	Locates the noise
(J-43980) NISSAN Squeak and Rattle Kit   SIIA0994E	Repairs the cause of noise

#### Commercial Service Tools

INFOID:000000006456826

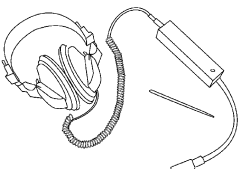
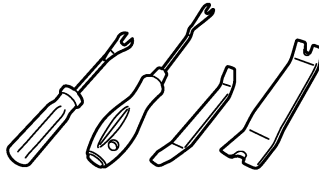
Tool name	Description
Engine ear   SIIA0995E	Locates the noise
Remover tool   JMKIA3050ZZ	Removes clips, pawls and metal clips

# CLIP LIST

< PREPARATION >

## CLIP LIST

### Clip List

INFOID:000000006456827

Shapes	Removal & Installation	Shapes	Removal & Installation
	<p><b>Removal:</b> Remove by bending up with flat-bladed screwdrivers or clip remover.</p>		<p><b>Removal:</b></p>
	<p><b>Removal:</b> Remove with a clip remover.</p>		<p><b>Removal:</b></p>
	<p><b>Removal:</b> Push center pin to catching position. (Do not remove center pin by hitting it.)</p> <p><b>Installation:</b></p>		<p><b>Removal:</b> Holder portion of clip must be spread out to remove rod.</p>
	<p><b>Removal:</b> Remove by bending up with flat-bladed screwdrivers or clip remover.</p>		<p><b>Removal:</b></p> <ol style="list-style-type: none"> <li>Screw out with a Phillips screwdriver.</li> <li>Remove female portion with flat-bladed screwdriver.</li> </ol>
	<p><b>Removal:</b></p>		<p><b>Removal:</b></p> <p><b>Installation:</b></p>
	<p><b>Removal:</b></p>		<p><b>Removal:</b></p>

JMJIA3734GB

A  
B  
C  
D  
E  
F  
G  
H  
I  
INT  
K  
L  
M  
N  
O  
P

# DOOR FINISHER

< REMOVAL AND INSTALLATION >

## REMOVAL AND INSTALLATION

### DOOR FINISHER

Exploded View

INFOID:000000006456828

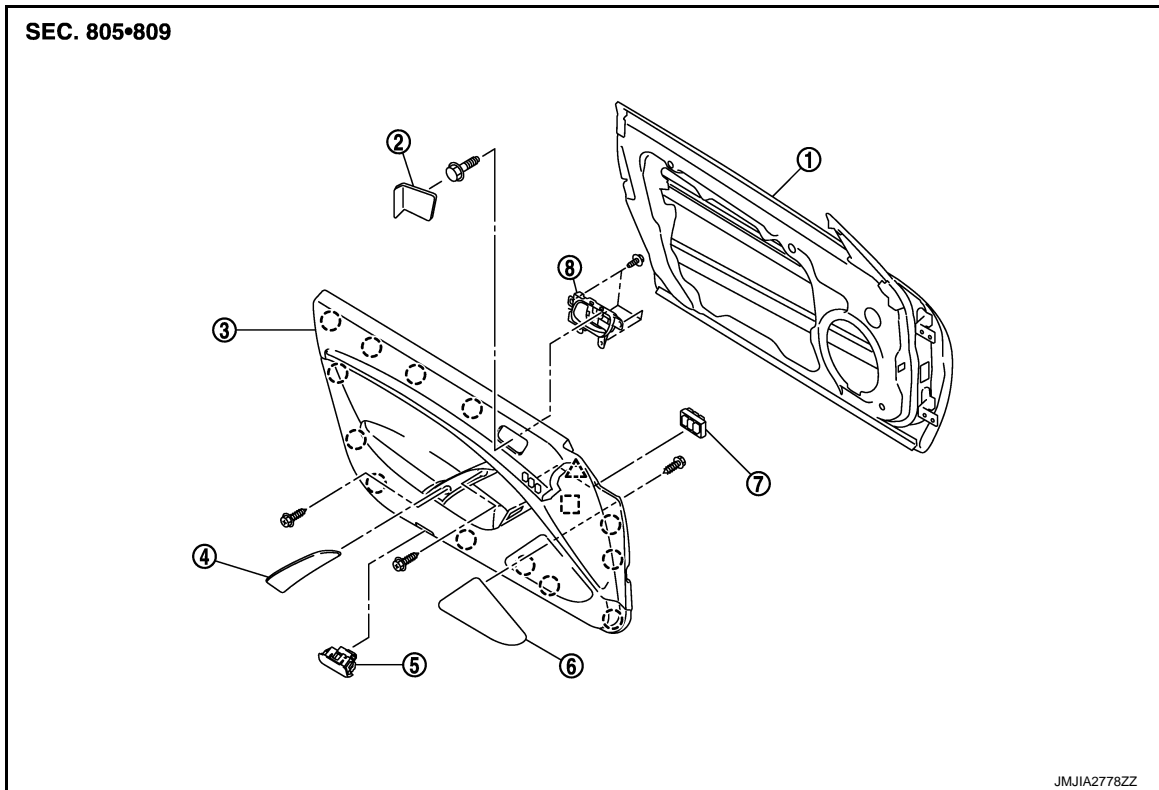

- |                        |                             |                           |
|------------------------|-----------------------------|---------------------------|
| 1. Door panel assembly | 2. Inside handle escutcheon | 3. Door finisher assembly |
| 4. Armrest cap         | 5. Step lamp                | 6. Speaker grille         |
| 7. Seat memory switch  | 8. Inside handle            |                           |

- : Clip  
△ : Pawl  
□ : Metal clip

### Removal and Installation

INFOID:000000006456829

#### CAUTION:

When removing, always use a remover tool that is made of plastic.

#### REMOVAL

1. Fully open door window.
2. Remove inside handle escutcheon (1) with remover tool (A).

- △ : Pawl

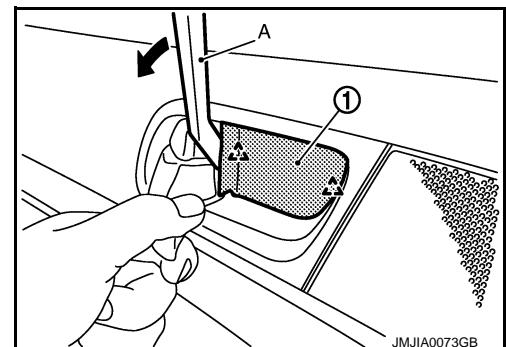

# DOOR FINISHER

## < REMOVAL AND INSTALLATION >

3. Remove bolt (A), located behind the inside handle escutcheon.

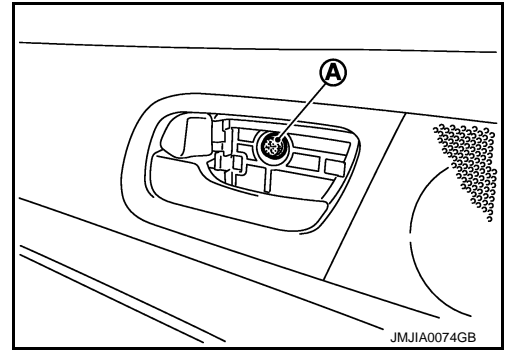

4. Remove armrest cap (1) with remover tool (A).

 : Pawl

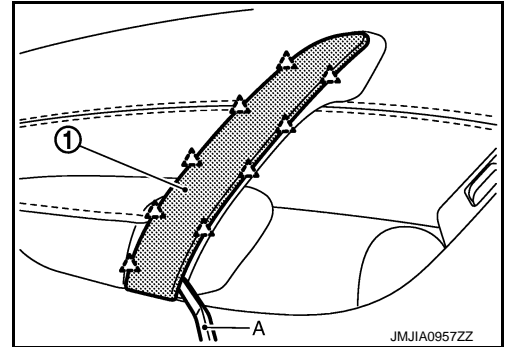

5. Remove screws (A), located behind the armrest cap.

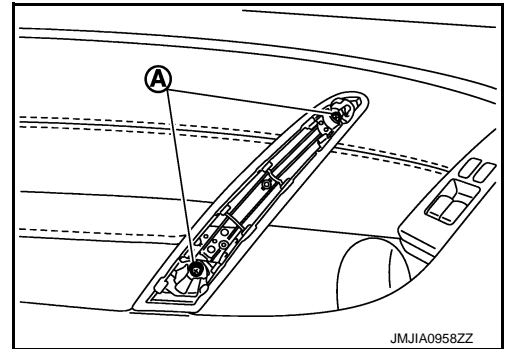

6. Remove step lamp (1).  
Refer to [INL-110. "Removal and Installation"](#).

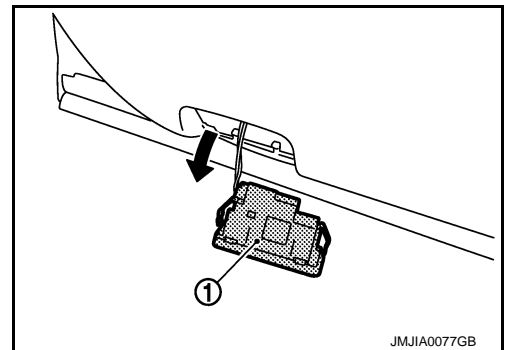

7. Insert a remover tool (A) into clips on door finisher (1), and disengage clips.

 : Clip

**CAUTION:**  
Insert a remover tool into the part shown in the figure.  
(Between the clips and the body side panel).

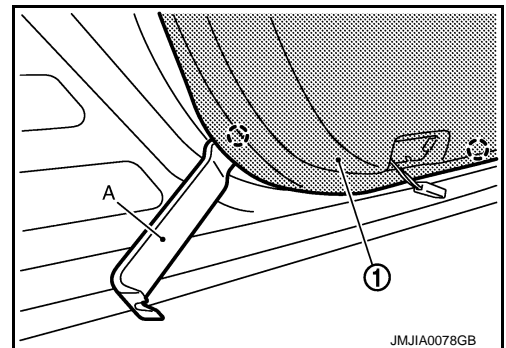

A  
B  
C  
D  
E  
F  
G  
H  
I  
INT  
K  
L  
M  
N  
O  
P

# DOOR FINISHER

## < REMOVAL AND INSTALLATION >

8. Pull up door finisher and pull out toward vehicle inside.
  - Disconnect seat memory switch connector (A) (with ADP).
  - Disconnect tweeter connector (B) (with BASE AUDIO).
  - Disconnect door squawker connector (B) (with BOSE AUDIO).

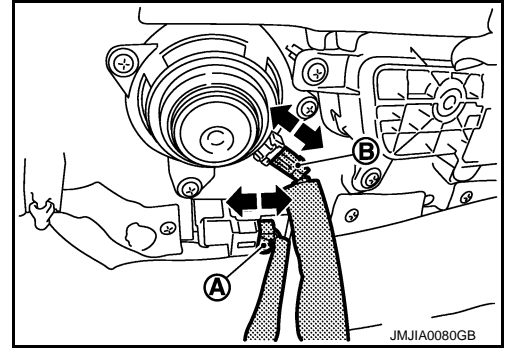

9. Disconnect the inside handle cable from door inside handle assembly. Refer to [DLK-236, "INSIDE HANDLE : Exploded View"](#).
10. Disconnect power window switch connector and mirror control switch connector.
11. Remove door finisher.
12. Remove the following parts after removing door finisher.
  - Door inside handle assembly. Refer to [DLK-236, "INSIDE HANDLE : Exploded View"](#).
  - Seat memory switch (with ADP). Refer to [ADP-236, "Removal and Installation"](#).
  - Tweeter.  
Refer to [AV-94, "Removal and Installation"](#) (with BASE AUDIO).  
Refer to [AV-336, "Removal and Installation"](#) (with BOSE AUDIO).
  - Door squawker (with BOSE AUDIO) Refer to [AV-333, "Removal and Installation"](#).

## INSTALLATION

Install in the reverse order of removal.

### **CAUTION:**

**When installing door finisher, check that clips are securely fitted in panel holes on body, and then press them in.**

# BODY SIDE TRIM

< REMOVAL AND INSTALLATION >

## BODY SIDE TRIM

Exploded View

INFOID:000000006456830

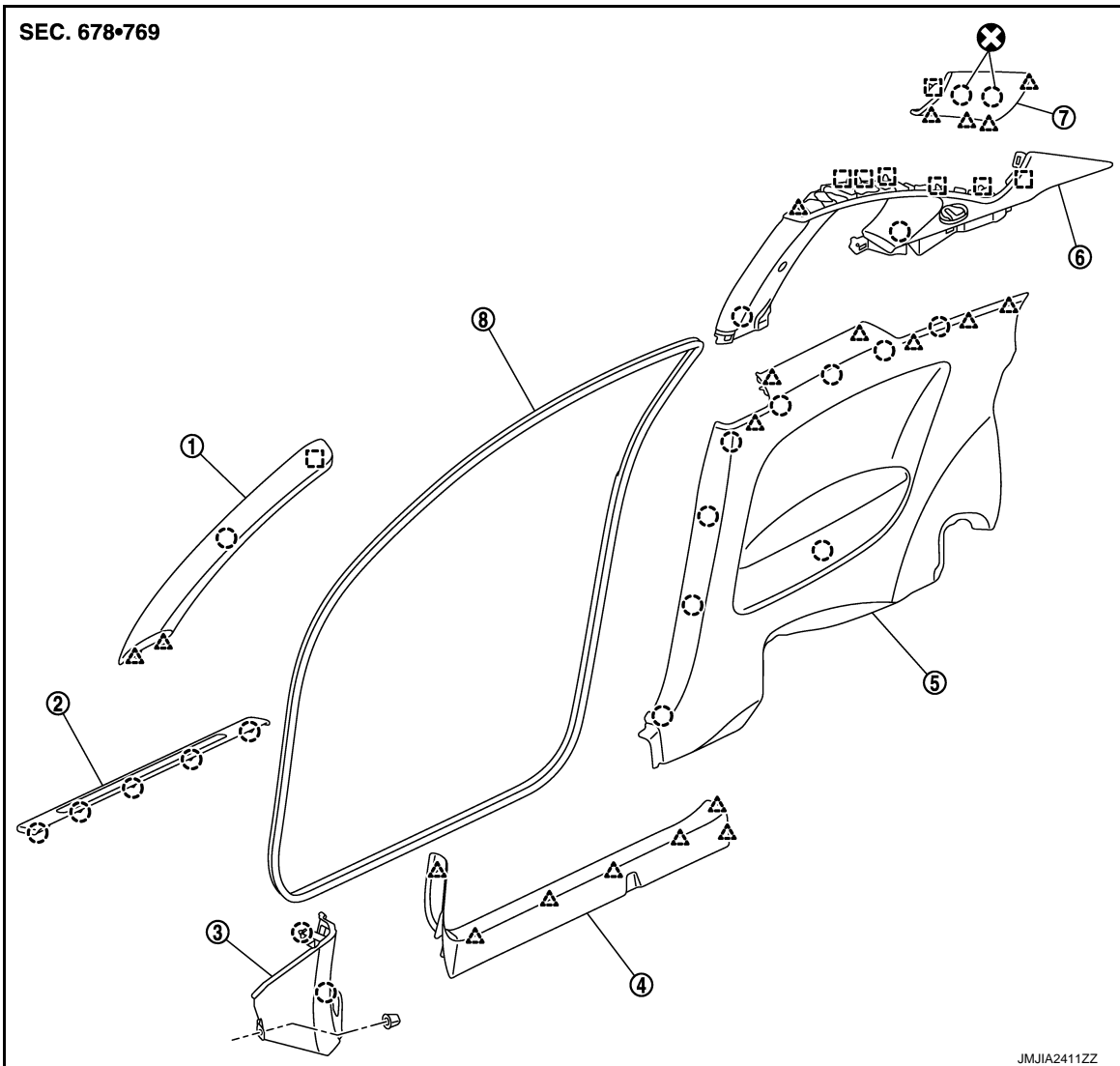

- |                         |                        |                         |
|-------------------------|------------------------|-------------------------|
| 1. Front pillar garnish | 2. Kicking plate outer | 3. Dash side finisher   |
| 4. Kicking plate inner  | 5. Rear side finisher  | 6. Rear pillar finisher |
| 7. Back pillar garnish  | 8. Body side welt      |                         |

○ : Clip

△ : Pawl

□ : Metal clip

Refer to [GI-4. "Components"](#) for the symbols in the figure.

### Removal and Installation

INFOID:000000006456831

#### CAUTION:

- When removing, always use a remover tool that is made of plastic.
- Never damage the body.

#### REMOVAL

##### FRONT PILLAR GARNISH

1. Release front pillar portion of body side welt.

A  
B  
C  
D  
E  
F  
G  
H  
I  
INT  
K  
L  
M  
N  
O  
P

# BODY SIDE TRIM

## < REMOVAL AND INSTALLATION >

2. Remove front pillar garnish fixing clip and metal clip with a remover tool (A), and then remove front pillar garnish (1).

- : Clip
- : Metal clip

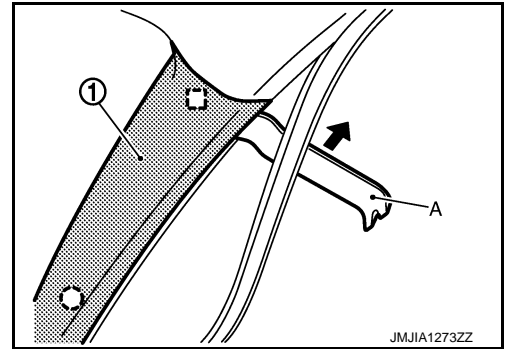

## DASH SIDE FINISHER

1. Remove instrument passenger lower cover.  
Refer to [IP-13. "A/T MODELS : Removal and Installation"](#) (A/T models).  
Refer to [IP-24. "M/T MODELS : Removal and Installation"](#) (M/T models).
2. Remove kicking plate inner.
3. Remove clip (A).
4. Remove dash side finisher fixing clips with a remover tool (B), and then remove dash side finisher (1).

- : Clip

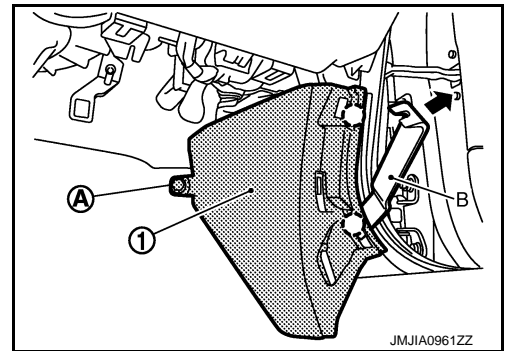

## KICKING PLATE OUTER

Remove kicking plate outer fixing clips with a remover tool (A), and then remove kicking plate outer (1).

- : Clip

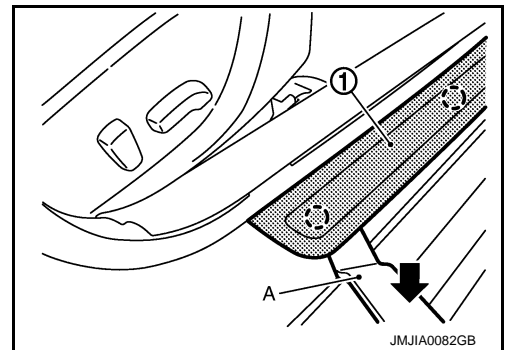

## KICKING PLATE INNER

1. Disengage kicking plate inner mounting pawl on portion (A) as shown in the figure using a remover tool (D).
2. Disengage kicking plate inner mounting pawls on portion (B) as shown in the figure using a remover tool (D).

### **CAUTION:**

**Apply protective tape (E) on the parts to protect it from damage.**



# BODY SIDE TRIM

## < REMOVAL AND INSTALLATION >

3. Pull kicking plate inner toward vehicle rear while pressing front end of kicking plate inner downward, disengage kicking plate inner mounting pawl on portion (C) as shown in the figure, and then remove kicking plate inner.

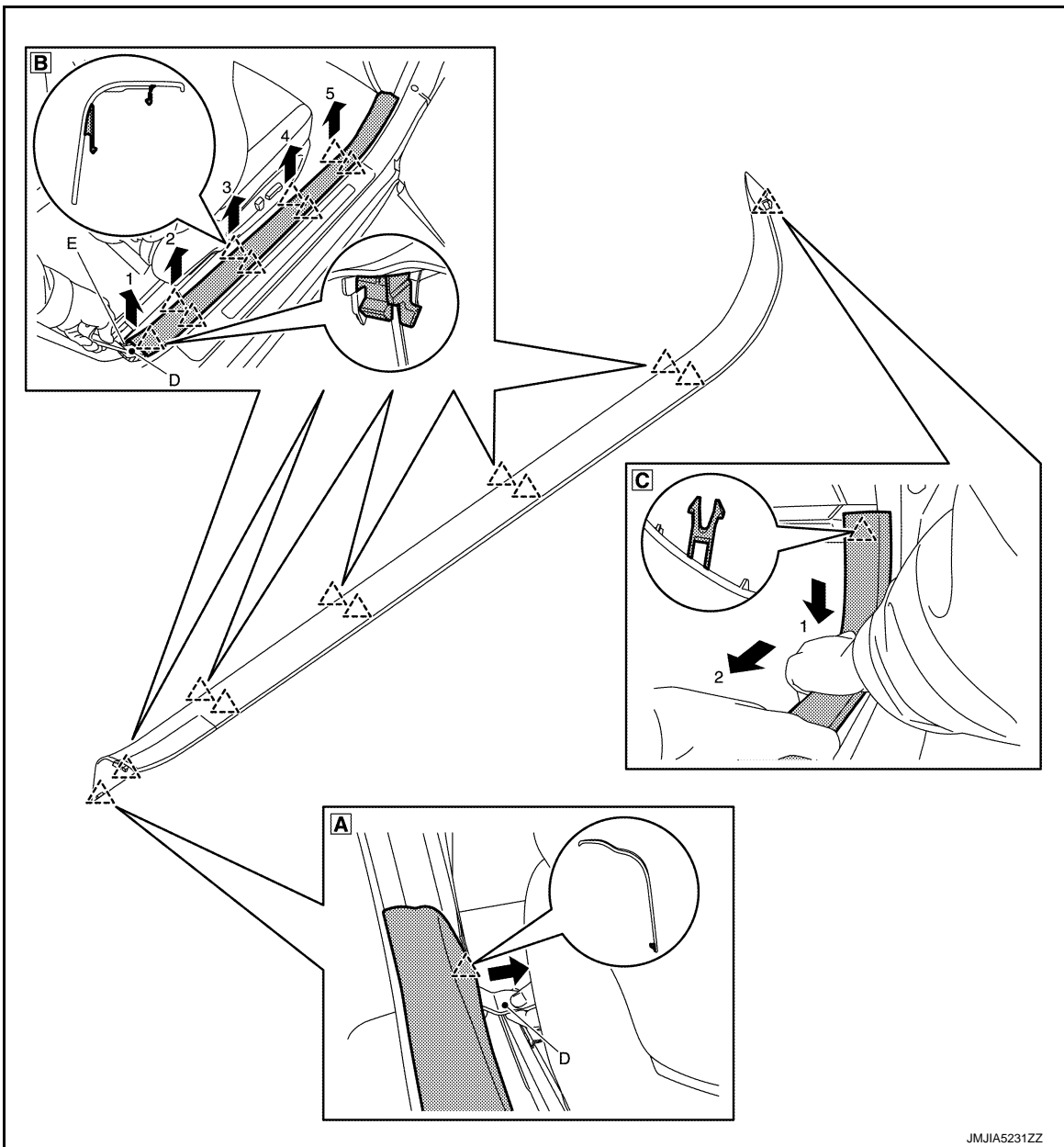

△ : Pawl

### BODY SIDE WELT

1. Remove kicking plate inner.
2. Remove body side welt.

### REAR SIDE FINISHER

1. Remove rear seat cushion and rear seatback. Refer to [SE-201. "Removal and Installation"](#).
2. Remove body side welt.

A  
B  
C  
D  
E  
F  
G  
H  
I  
INT  
K  
L  
M  
N  
O  
P

## BODY SIDE TRIM

### < REMOVAL AND INSTALLATION >

3. Remove rear side finisher (1) fixing clips with a remover tool (A), and then disconnect rear speaker harness connector.

 : Clip

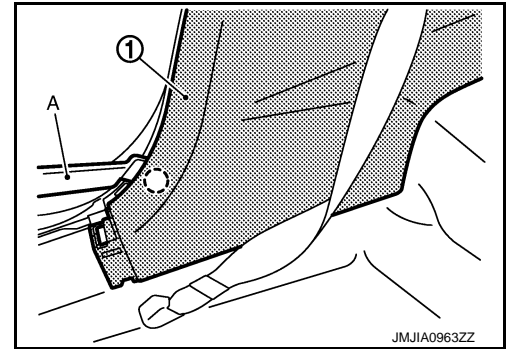



4. Remove rear side finisher.

### BACK PILLAR GARNISH

1. Remove back pillar garnish (1) fixing clips and pawls with a remover tool (A).
2. Remove back pillar garnish (1) from rear pillar finisher (2).

 : Clip

 : Pawl

 : Metal clip

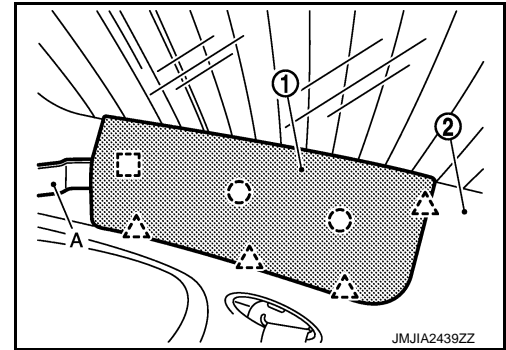

### REAR PILLAR FINISHER

1. Remove rear seat cushion and rear seatback. Refer to [SE-201, "Removal and Installation"](#).
2. Remove body side welt.
3. Remove rear side finisher.
4. Remove front seat belt floor anchor bolt. Refer to [SB-8, "SEAT BELT BUCKLE : Exploded View"](#).
5. Remove rear seat belt floor anchor bolt. Refer to [SB-12, "SEAT BELT BUCKLE : Exploded View"](#).
6. Remove rear seat belt escutcheon fixing pawls with remover tool (A), and then remove rear seat belt escutcheon (1) from rear pillar finisher (2).

 : Pawl

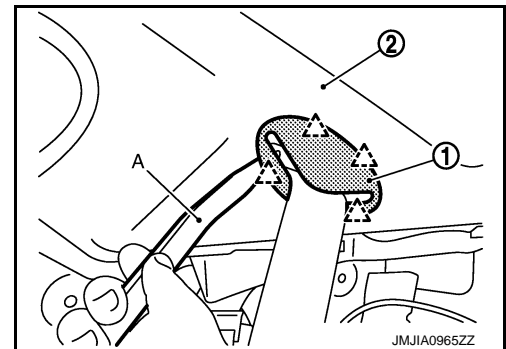

7. Remove back pillar garnish.
8. Remove rear pillar finisher fixing clips, pawl, metal clips with a remover tool, and then remove rear pillar finisher.

### INSTALLATION

Install in the reverse order of removal.

#### **CAUTION:**

**Check that clips are securely fitted in panel holes on body when installing, and then press them in.**

# REAR PARCEL SHELF FINISHER

< REMOVAL AND INSTALLATION >

## REAR PARCEL SHELF FINISHER

Exploded View

INFOID:000000006456832

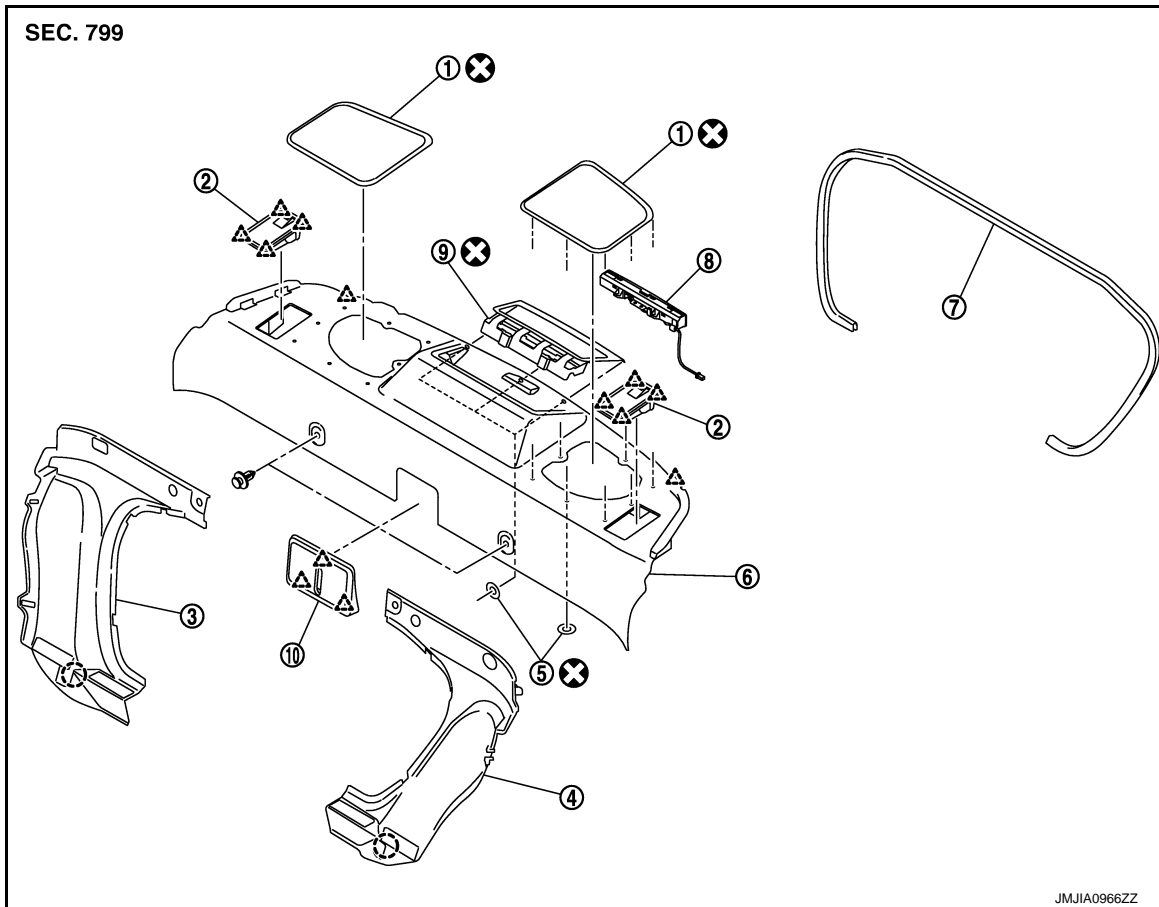

- |                              |                                    |                                 |
|------------------------------|------------------------------------|---------------------------------|
| 1. Rear speaker grille       | 2. Child anchor cover              | 3. Rear seatback finisher RH    |
| 4. Rear seatback finisher LH | 5. Push on nut                     | 6. Rear parcel shelf finisher   |
| 7. Rear seatback welt        | 8. High-mounted stop lamp assembly | 9. High-mounted stop lamp cover |
| 10. Rear seat striker cover  |                                    |                                 |

- : Clip  
△ : Pawl

Refer to [GI-4. "Components"](#) for symbols in the figure.

### Removal and Installation

INFOID:000000006456833

#### REMOVAL

1. Remove trunk front finisher upper (without REAR SPOILER). Refer to [INT-29. "Removal and Installation"](#).

## REAR PARCEL SHELF FINISHER

### < REMOVAL AND INSTALLATION >

2. Disconnect high-mounted stop lamp harness connector (A).  
(without REAR SPOILER)

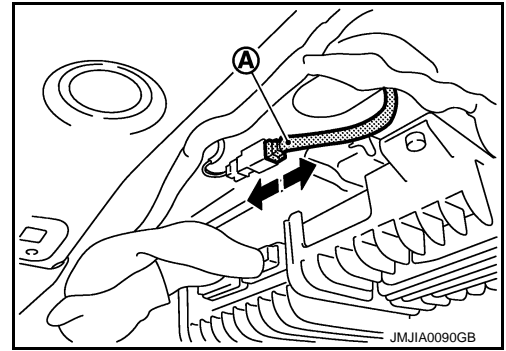

3. Remove rear seat cushion and rear seatback. Refer to [SE-201, "Removal and Installation"](#).
4. Remove rear side finisher and rear pillar finisher. Refer to [INT-15, "Removal and Installation"](#).
5. Remove rear parcel shelf finisher fixing clips (A).

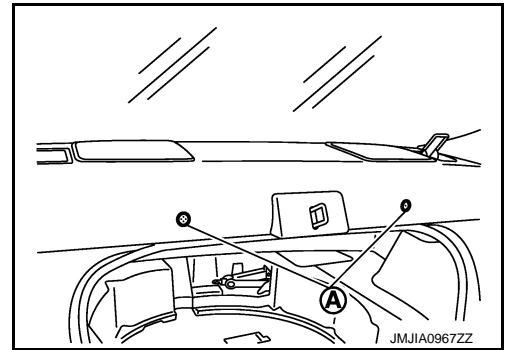

6. Remove rear seat striker cover fixing pawls, and then remove rear seat striker cover.
7. Pull rear parcel shelf finisher, and then remove rear parcel shelf finisher.
8. Remove the following parts after removing rear parcel shelf finisher.
  - Child anchor cover.
  - Rear speaker grille.
  - High-mounted stop lamp (without REAR SPOILER). Refer to [EXL-178, "WITHOUT REAR SPOILER : Removal and Installation"](#).

### INSTALLATION

Install in the reverse order of removal.

#### **CAUTION:**

**Check that clips are securely fitted in panel holes on body when installing, and then press them in.**

# FLOOR TRIM

< REMOVAL AND INSTALLATION >

## FLOOR TRIM

Exploded View

INFOID:000000006456834

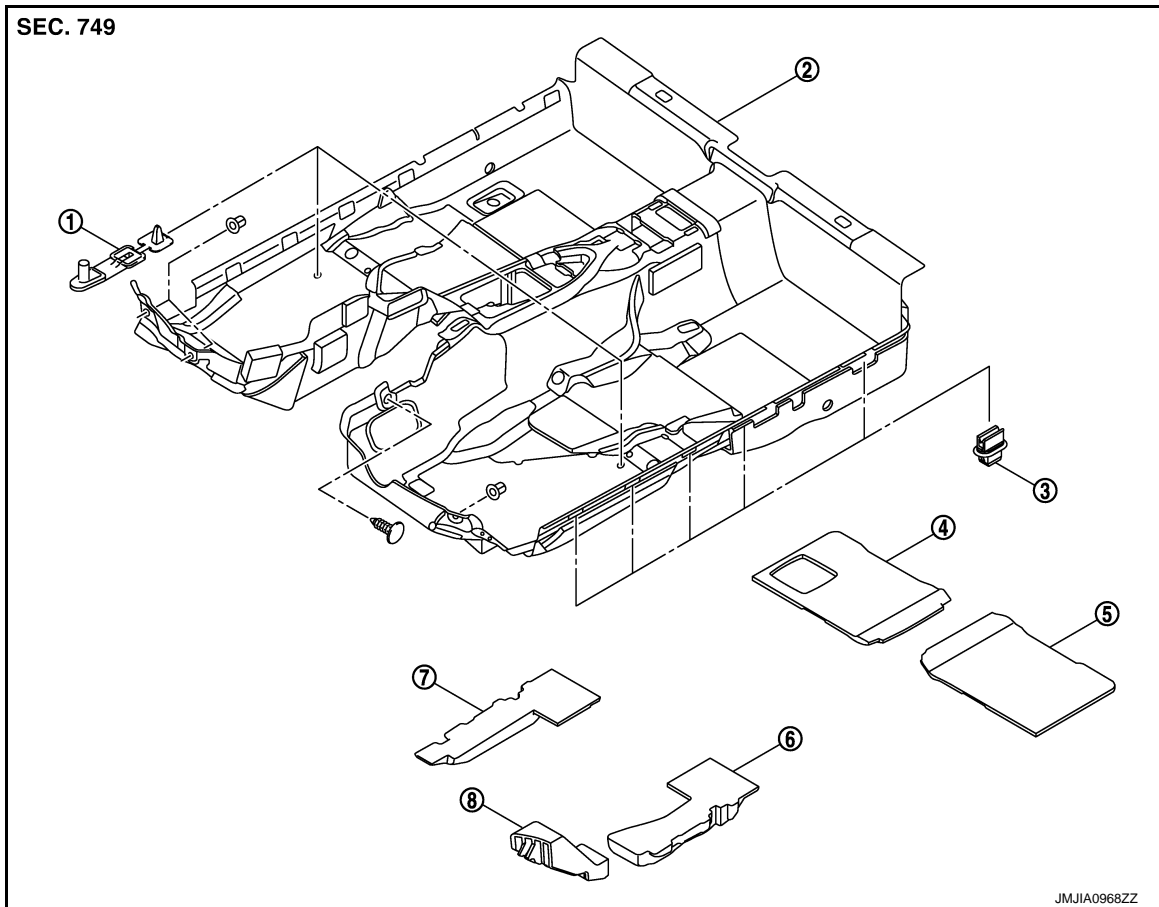

- |                            |                           |                            |
|----------------------------|---------------------------|----------------------------|
| 1. Floor hook              | 2. Floor trim             | 3. Fixing clip             |
| 4. Rear floor spacer (RH)  | 5. Rear floor spacer (LH) | 6. Front floor spacer (LH) |
| 7. Front floor spacer (RH) | 8. Footrest               |                            |

### Removal and Installation

INFOID:000000006456835

#### REMOVAL

1. Remove front seat assembly (LH/RH). Refer to [SE-191, "Removal and Installation"](#).
2. Remove rear seat cushion. Refer to [SE-201, "Removal and Installation"](#).
3. Remove accelerator pedal pad. Refer to [BR-18, "Removal and Installation"](#).
4. Disengage clip of floor hook (1) with remover tool (A).

 : Clip

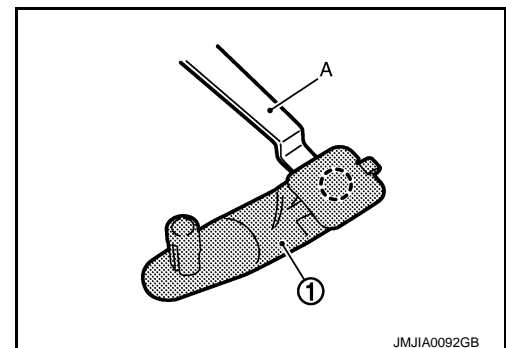

5. Remove foot grille. Refer to [VTL-13, "FOOT GRILLE : Removal and Installation"](#).

## FLOOR TRIM

### < REMOVAL AND INSTALLATION >

6. Remove front seat belt floor anchor bolt (LH/RH). Refer to [SB-8, "SEAT BELT BUCKLE : Exploded View"](#).
  7. Remove center console assembly.  
Refer to [IP-35, "A/T MODELS : Removal and Installation"](#) (A/T models).  
Refer to [IP-40, "M/T MODELS : Removal and Installation"](#) (M/T models).
  8. Remove instrument lower cover, instrument driver panel, instrument assist lower panel and instrument side panel (LH/RH).  
Refer to [IP-12, "A/T MODELS : Exploded View"](#) (A/T models).  
Refer to [IP-24, "M/T MODELS : Removal and Installation"](#) (M/T models).
  9. Remove YAW RATE/G-SENSOR (1).  
Refer to [BRC-120, "Removal and Installation"](#).
  10. Remove diagnosis sensor unit (2).  
Refer to [SR-23, "Removal and Installation"](#).
  11. Remove console rear bracket (3).  
Refer to [IP-35, "A/T MODELS : Removal and Installation"](#) (A/T models).  
Refer to [IP-40, "M/T MODELS : Removal and Installation"](#) (M/T models).
  12. Remove floor harness mounting clamps (A).
13. Remove dash side finisher (LH/RH), front kicking plate inner (LH/RH) and body side welt (LH/RH).  
Refer to [INT-15, "Removal and Installation"](#).
  14. Remove floor trim fixing clips and fixing nuts.
  15. Remove floor trim from floor trim fixing clips (A) and remove floor carpet (1).

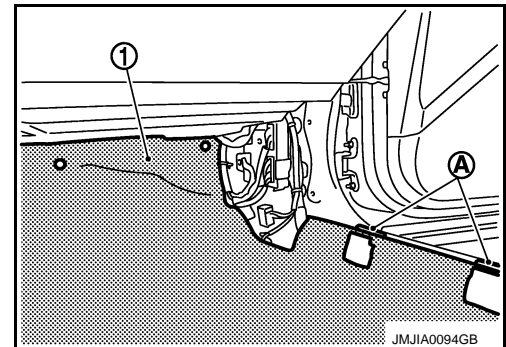
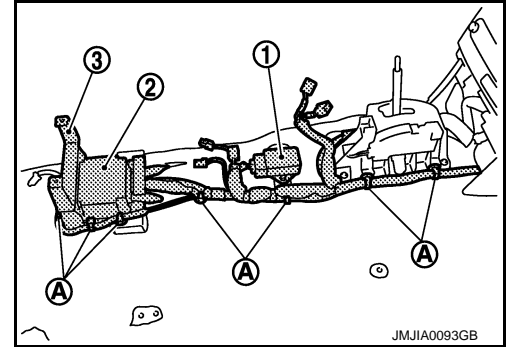

### INSTALLATION

Install in the reverse order of removal.

# HEADLINING

< REMOVAL AND INSTALLATION >

## HEADLINING NORMAL ROOF

### NORMAL ROOF : Exploded View

INFOID:000000006456836

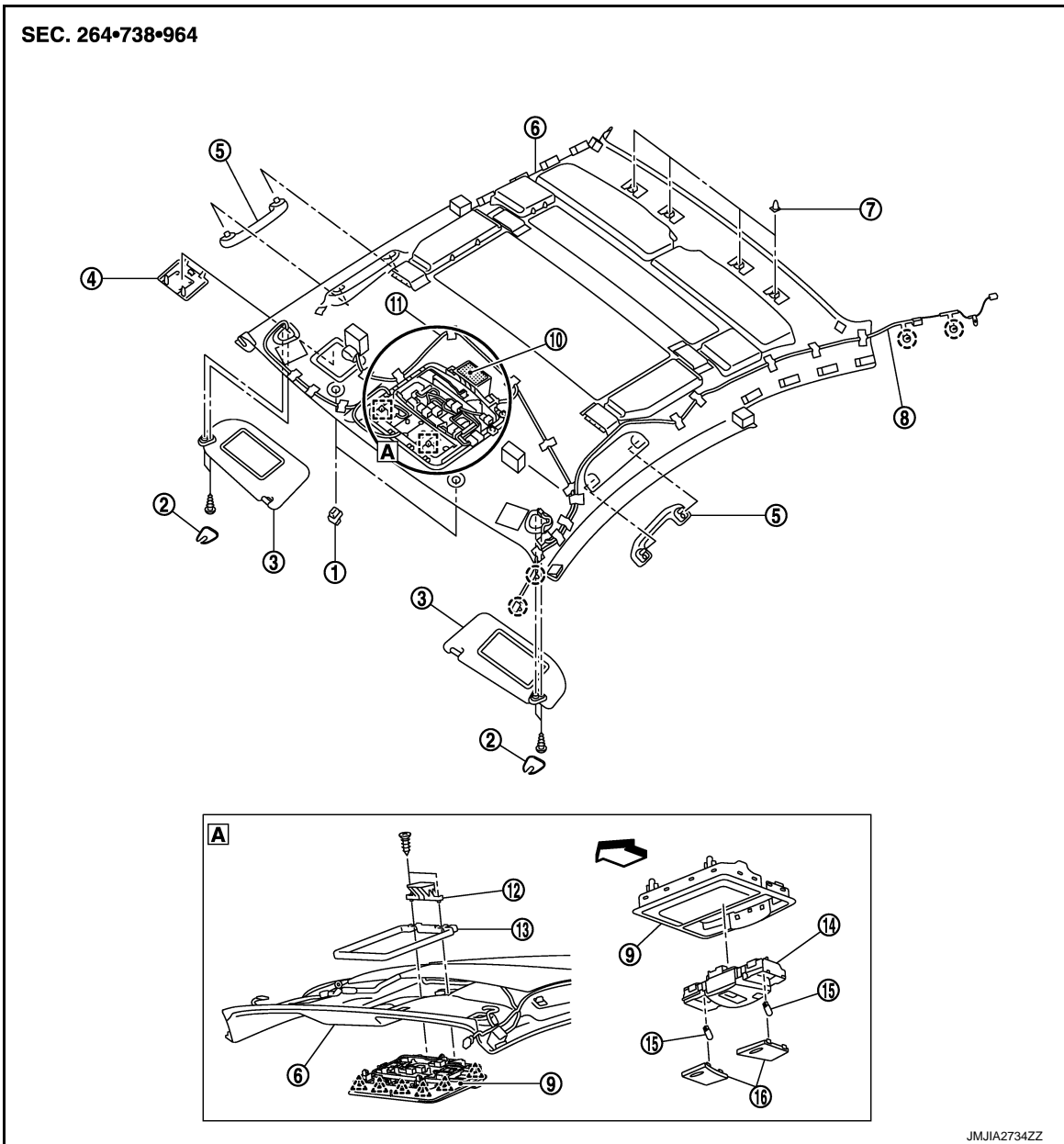

- |                           |                       |                            |
|---------------------------|-----------------------|----------------------------|
| 1. Sun visor holder       | 2. Sun visor cover    | 3. Sun visor assembly      |
| 4. Roof front finisher    | 5. Assist grip        | 6. Headlining assembly     |
| 7. Rear hidden clip       | 8. Antenna feeder     | 9. Roof console assembly   |
| 10. Dual lock fastener    | 11. Roof harness      | 12. Roof bracket           |
| 13. Roof plate assembly   | 14. Map lamp assembly | 15. Map lamp bulbs (LH/RH) |
| 16. Map lamp lens (LH/RH) |                       |                            |

○ : Clip

△ : Pawl

□ : Metal clip

⇨ : Vehicle front

JMJIA2734ZZ

A  
B  
C  
D  
E  
F  
G  
H  
I  
INT  
K  
L  
M  
N  
O  
P

# HEADLINING

## < REMOVAL AND INSTALLATION >

### NORMAL ROOF : Removal and Installation

INFOID:00000006456837



#### REMOVAL

1. Remove front pillar garnish (LH/RH) and body side welt (LH/RH). Refer to [INT-15, "Removal and Installation"](#).
2. Remove antenna feeder fixing clips with a remover tool after removing front pillar garnish (LH), then disconnect antenna feeder connectors (A).

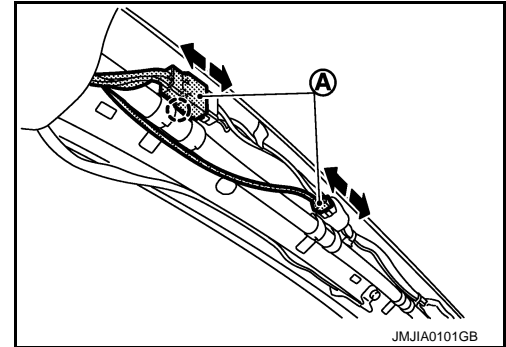
 : Clip



3. Remove front roof finisher fixing metal clips and pawls with a remover tool (A), and then remove front roof finisher (1).

 : Pawl  
 : Metal clip

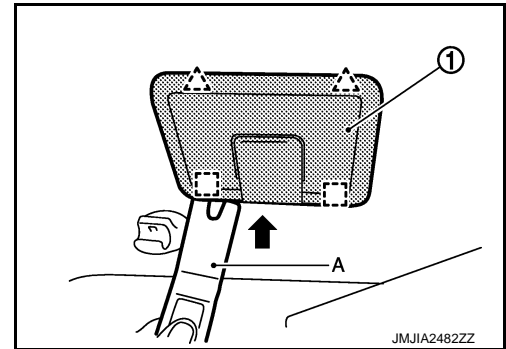

4. Remove sun visor assembly (LH/RH).
  - Remove sun visor cover.
  - Remove sun visor assembly mounting screws.
  - Disconnect vanity mirror lamp harness connectors.
5. Rotate 45 degrees and remove sun visor holder (1) (LH/RH).

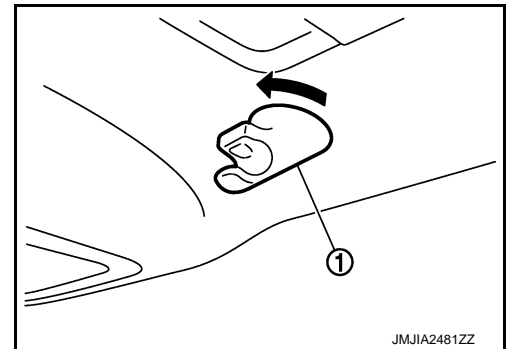

6. Remove fixing plastic clips (A) using a screwdriver (B) of front and rear assistance grips (1), and then remove assist grips.

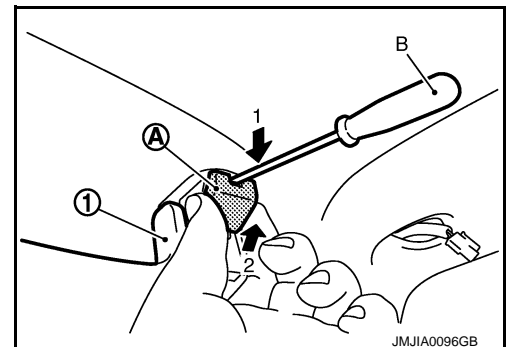

7. Remove rear seat cushion and seatback. Refer to [SE-201, "Removal and Installation"](#).



# HEADLINING

## < REMOVAL AND INSTALLATION >

- Remove front kicking plate inner (LH/RH), rear side finisher (LH/RH), rear pillar finisher (LH/RH). Refer to [INT-15, "Removal and Installation"](#).
- Disconnect antenna feeder connectors (A) of antenna amplifier and sub-antenna feeder (1) after removing rear pillar finisher (LH), and then remove antenna feeder fixing clip and ground cable fixing bolt (B).

 : Clip

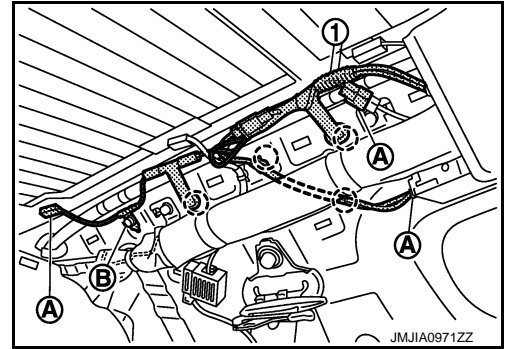

- With a remover tool, remove body side fixing plastic clip from rear end of headlining.
- Pull the roof console assembly toward vehicle lower, and disengage the metal clips (B) and the dual-lock fastener (A).

### CAUTION:

**Roof console assembly is crimped from back of headlining. Remove it by disengaging the crimped area of back of roof console assembly after removing headlining from the vehicle.**

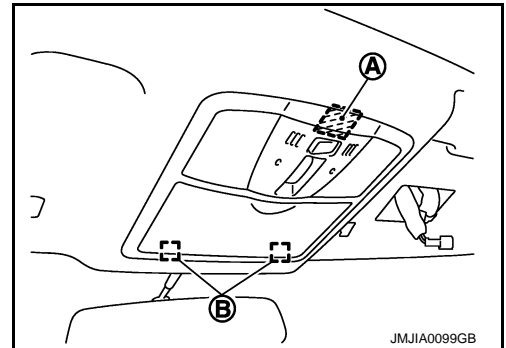

- Put front seat to front most and recline seat back to backward.
- Remove headlining (1), turn and take out from right side door.

### CAUTION:

- When removing the headlining, 2 workers are required. (1 for the front and rear of headlining)
- Cover center console finisher upper surface with a shop cloth to prevent it from being damaged.
- Never bend headlining when removing.

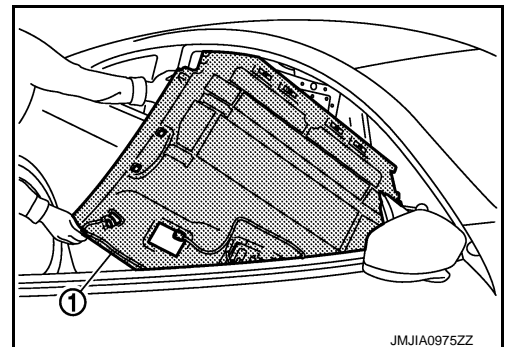

- Remove the following parts after removing headlining.
  - Map lamp assembly (without LDW system). Refer to [INT-23, "NORMAL ROOF : Exploded View"](#).
  - Roof harness assembly.
  - Antenna feeder assembly.

## INSTALLATION

Install in the reverse order of removal.

### CAUTION:

- Install headlining assembly after inserting clips to clip holder of headlining rear end.
- Never bend headlining when installing.

## SUNROOF

A  
B  
C  
D  
E  
F  
G  
H  
I  
INT  
K  
L  
M  
N  
O  
P

# HEADLINING

< REMOVAL AND INSTALLATION >

## SUNROOF : Exploded View

INFOID:000000006456838

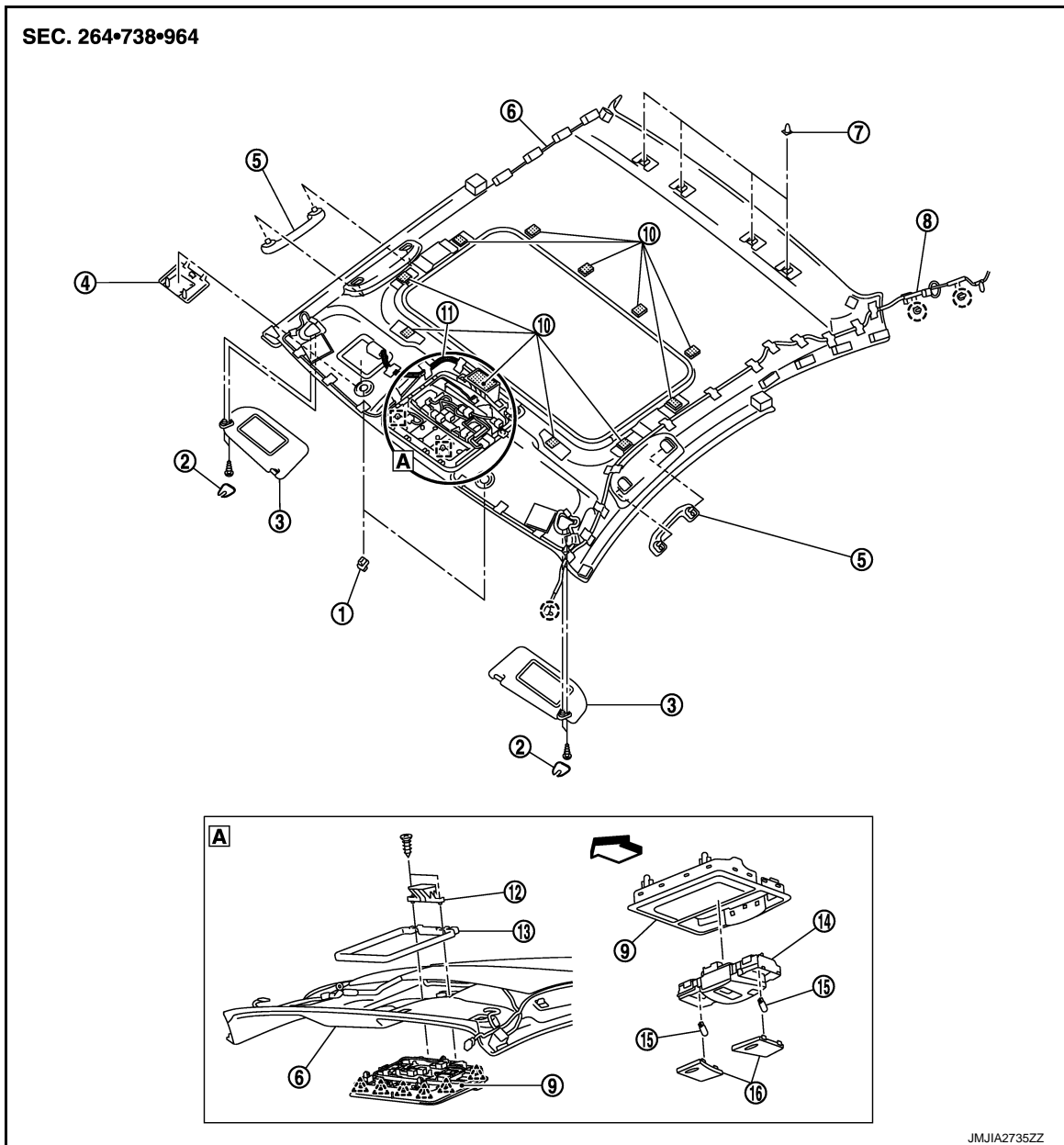

JMJIA2735ZZ

- |                           |                       |                            |
|---------------------------|-----------------------|----------------------------|
| 1. Sun visor holder       | 2. Sun visor cover    | 3. Sun visor assembly      |
| 4. Roof front finisher    | 5. Assist grip        | 6. Headlining assembly     |
| 7. Rear hidden clip       | 8. Antenna feeder     | 9. Roof console assembly   |
| 10. Dual lock fastener    | 11. Roof harness      | 12. Roof bracket           |
| 13. Roof plate assembly   | 14. Map lamp assembly | 15. Map lamp bulbs (LH/RH) |
| 16. Map lamp lens (LH/RH) |                       |                            |

○ : Clip

△ : Pawl

□ : Metal clip

← : Vehicle front

## SUNROOF : Removal and Installation

INFOID:000000006456839

### REMOVAL

Revision: 2011 December

**INT-26**

2011 G Coupe

# HEADLINING

## < REMOVAL AND INSTALLATION >

1. Remove front pillar garnish (LH/RH) and body side welt (LH/RH). Refer to [INT-15, "Removal and Installation"](#).
2. Remove antenna feeder fixing clips with a remover tool after removing front pillar garnish (LH), then disconnect antenna feeder connectors (A).

 : Clip

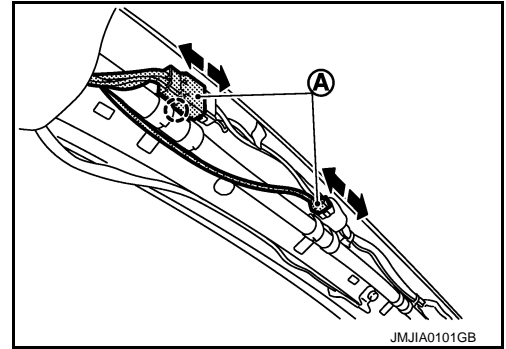

3. Remove front roof finisher fixing metal clips and pawls with a remover tool (A), and then remove front roof finisher (1).

 : Pawl

 : Metal clip

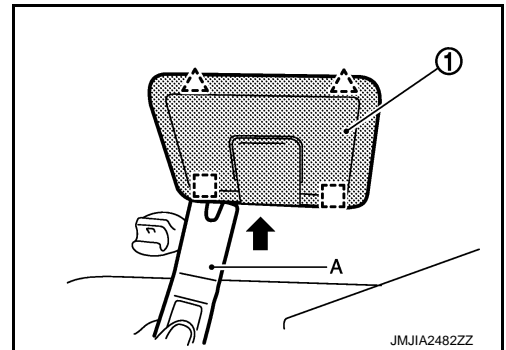

4. Remove sun visor assembly (LH/RH).
  - Remove sun visor cover.
  - Remove sun visor assembly mounting screws.
  - Disconnect vanity mirror lamp harness connectors.
5. Rotate 45 degrees and remove sun visor holder (1) (LH/RH).

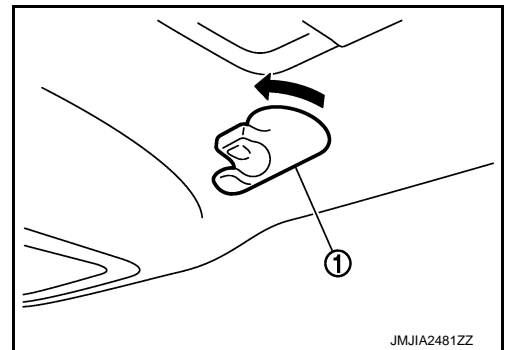

6. Remove fixing plastic clips (A) using a screwdriver (B) of front and rear assistance grips (1), and then remove assist grips.

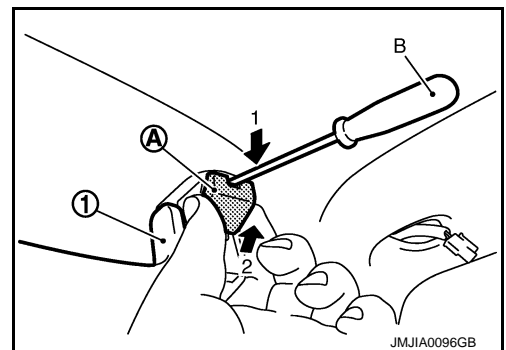

7. Remove rear seat cushion and seatback. Refer to [SE-201, "Removal and Installation"](#).
8. Remove front kicking plate inner (LH/RH), rear side finisher (LH/RH), rear pillar finisher (LH/RH). Refer to [INT-15, "Removal and Installation"](#).

A  
B  
C  
D  
E  
F  
G  
H  
I  
INT  
K  
L  
M  
N  
O  
P

# HEADLINING

## < REMOVAL AND INSTALLATION >

9. Disconnect antenna feeder connectors (A) of antenna amplifier and sub-antenna feeder (1) after removing rear pillar finisher (LH), and then remove antenna feeder fixing clip and ground cable fixing bolt (B).

 : Clip

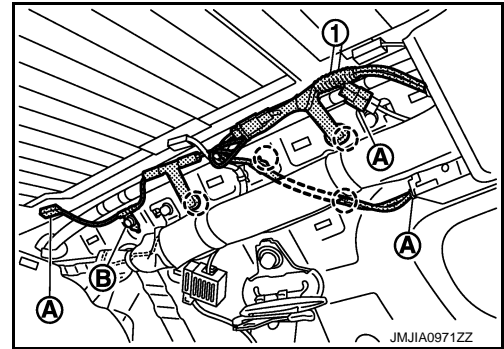

10. With a remover tool, remove body side fixing plastic clip from rear end of headlining.  
11. Pull the roof console assembly toward vehicle lower, and disengage the metal clips (B) and the dual-lock fastener (A).

### CAUTION:

Roof console assembly is crimped from back of headlining. Remove it by disengaging the crimped area of back of roof console assembly after removing headlining from the vehicle.

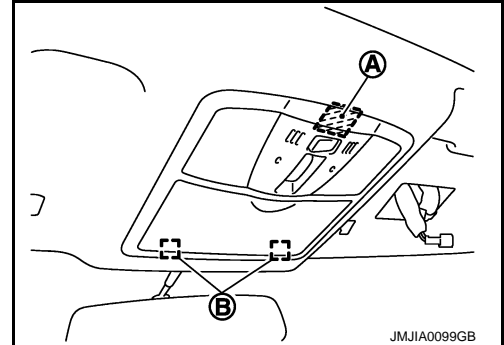

12. Put front seat to front most and recline seat back to backward.  
13. Remove headlining (1), turn and take out from right side door.

### CAUTION:

- When removing the headlining, 2 workers are required. (1 for the front and rear of headlining)
- Cover center console finisher upper surface with a shop cloth to prevent it from being damaged.
- Never bend headlining when removing.

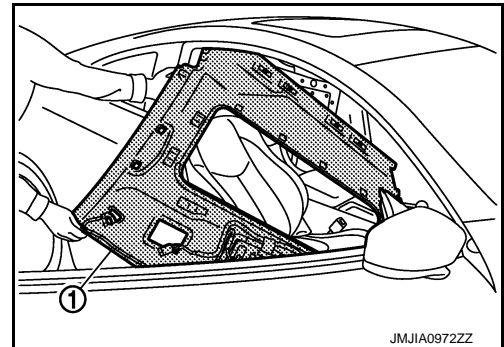

14. Remove the following parts after removing headlining.
- Map lamp assembly (without LDW system). Refer to [INT-26, "SUNROOF : Exploded View"](#).
  - Roof harness assembly.
  - Antenna feeder assembly.

## INSTALLATION

Install in the reverse order of removal.

### CAUTION:

- Install headlining assembly after inserting clips to clip holder of headlining rear end.
- Never bend headlining when installing.

# TRUNK ROOM TRIM

< REMOVAL AND INSTALLATION >

## TRUNK ROOM TRIM

Exploded View

INFOID:000000006456840

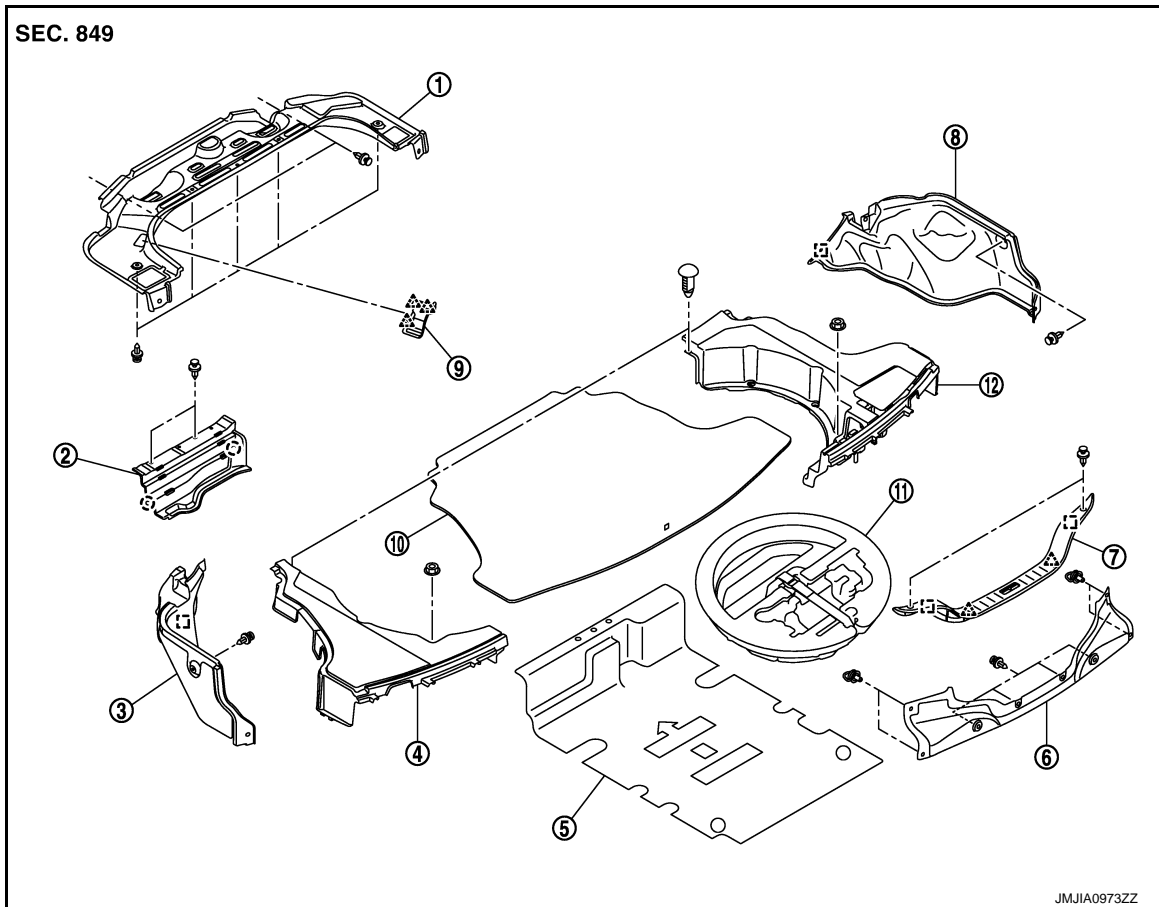

- |                               |                                   |                                       |
|-------------------------------|-----------------------------------|---------------------------------------|
| 1. Trunk front finisher upper | 2. Trunk floor cover              | 3. Rear wheel house finisher LH       |
| 4. Trunk floor spacer LH      | 5. Trunk floor felt               | 6. Trunk rear finisher                |
| 7. Trunk rear plate           | 8. Rear wheel house finisher (RH) | 9. Rear seat control lever escutcheon |
| 10. Trunk floor carpet        | 11. Trunk center box              | 12. Trunk floor spacer RH             |

○ : Clip

△ : Pawl

□ : Metal clip

## Removal and Installation

INFOID:000000006456841

### REMOVAL

1. Fully open trunk lid assembly.
2. Remove trunk floor carpet.
3. Remove trunk rear plate fixing clips, hold and pull the trunk rear plate to disengage the metal clip and then remove it.
4. Remove trunk floor cover fixing clips, and then remove trunk floor cover.
5. Remove trunk weather-strip.
6. Remove trunk rear finisher fixing clips and trunk net hook, and then remove trunk rear finisher.
7. Remove trunk center box.
8. Remove spare tire.(With spare tire)
9. Remove rear seatback welt. Refer to [INT-19, "Exploded View"](#).

## TRUNK ROOM TRIM

### < REMOVAL AND INSTALLATION >

---

10. Remove trunk front finisher fixing clips and metal clips, and then remove trunk front finisher.
11. Remove trunk side finisher fixing clip and metal clip, and then remove trunk side finisher (LH/RH).
12. Remove jack.
13. Remove the trunk floor spacer cover.
14. Remove trunk floor spacer mounting nuts, and then remove trunk floor spacer (LH/RH).

### INSTALLATION

Install in the reverse order of removal.

#### **CAUTION:**

**Check that clips, pawls, metal clips are securely fitted in panel holes on body when installing, and then press them in.**

# TRUNK LID TRIM

< REMOVAL AND INSTALLATION >

## TRUNK LID TRIM

Exploded View

INFOID:000000006456842

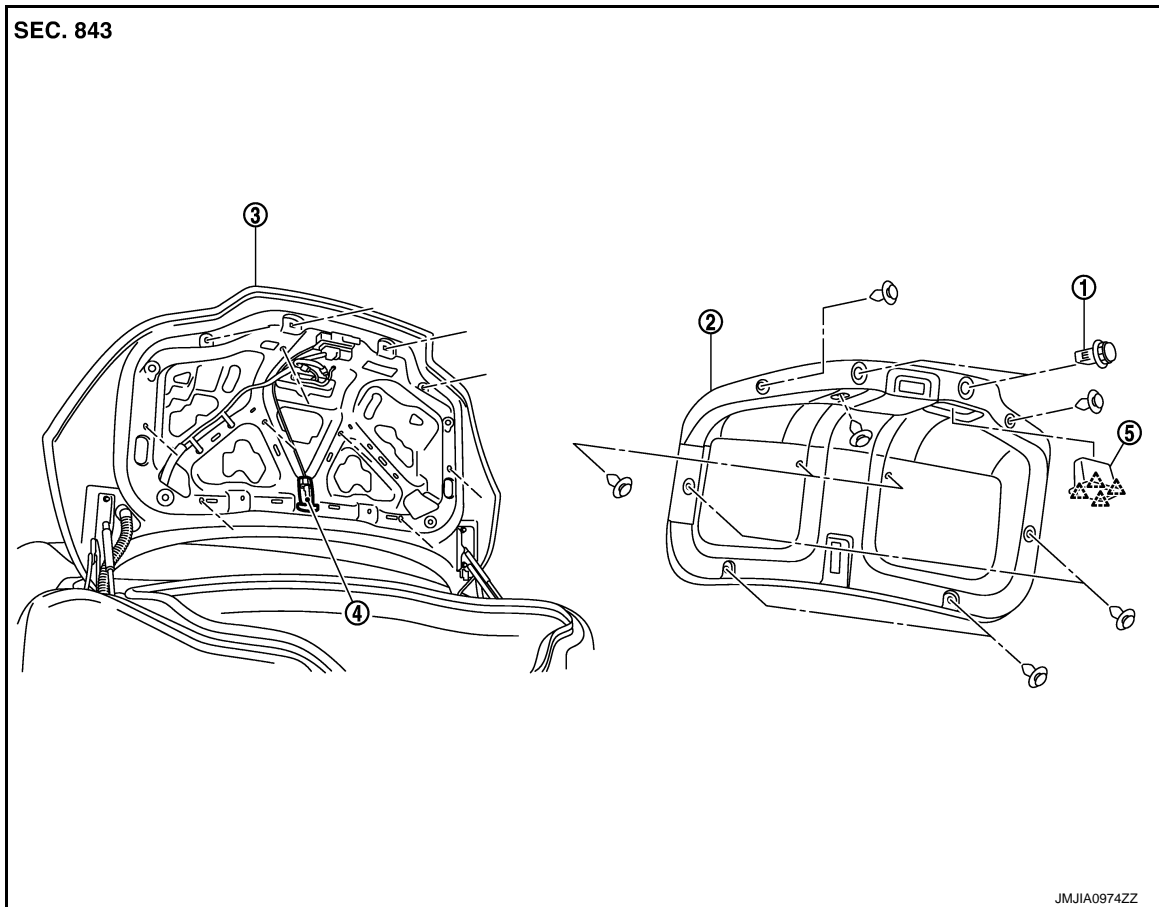

A  
B  
C  
D  
E  
F  
G  
H  
I

INT

K  
L  
M  
N  
O  
P

## Removal and Installation

INFOID:000000006456843

### REMOVAL

1. Fully open trunk lid assembly.
2. Remove trunk lid bumper rubber. Refer to [DLK-226, "TRUNK LID ASSEMBLY : Removal and Installation"](#).
3. Remove trunk lid pull handle (1).

△ : Pawl

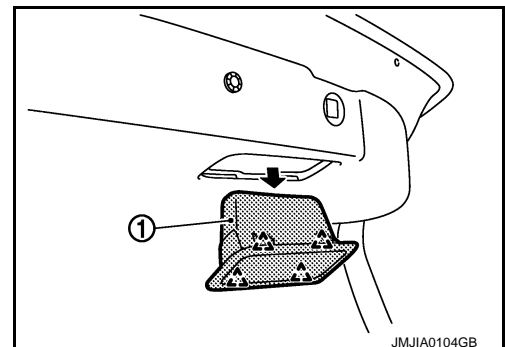

## TRUNK LID TRIM

### < REMOVAL AND INSTALLATION >

4. Remove trunk lid emergency handle holder (1).

 : Clip

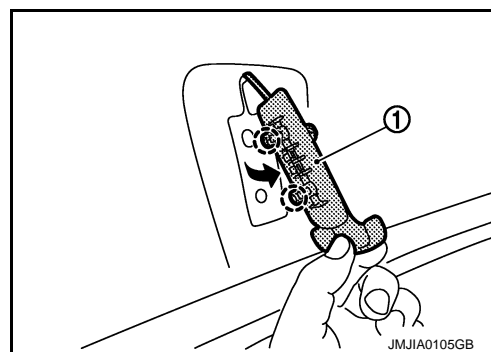

5. Remove trunk lid finisher fixing clips, and then remove trunk lid finisher inner.

### INSTALLATION

Install in the reverse order of removal.